

Core routers' architecture

www.huawei.com

Piotr Głaska, CCIE #15966
Enterprise IP Product Manager, CEE&Nordics

Marcin Mazur, CCIE #24210
IP Solutions Manager, CEE&Nordics

HUAWEI TECHNOLOGIES CO., LTD.



Huawei in numbers

Revenue (USD in billions)

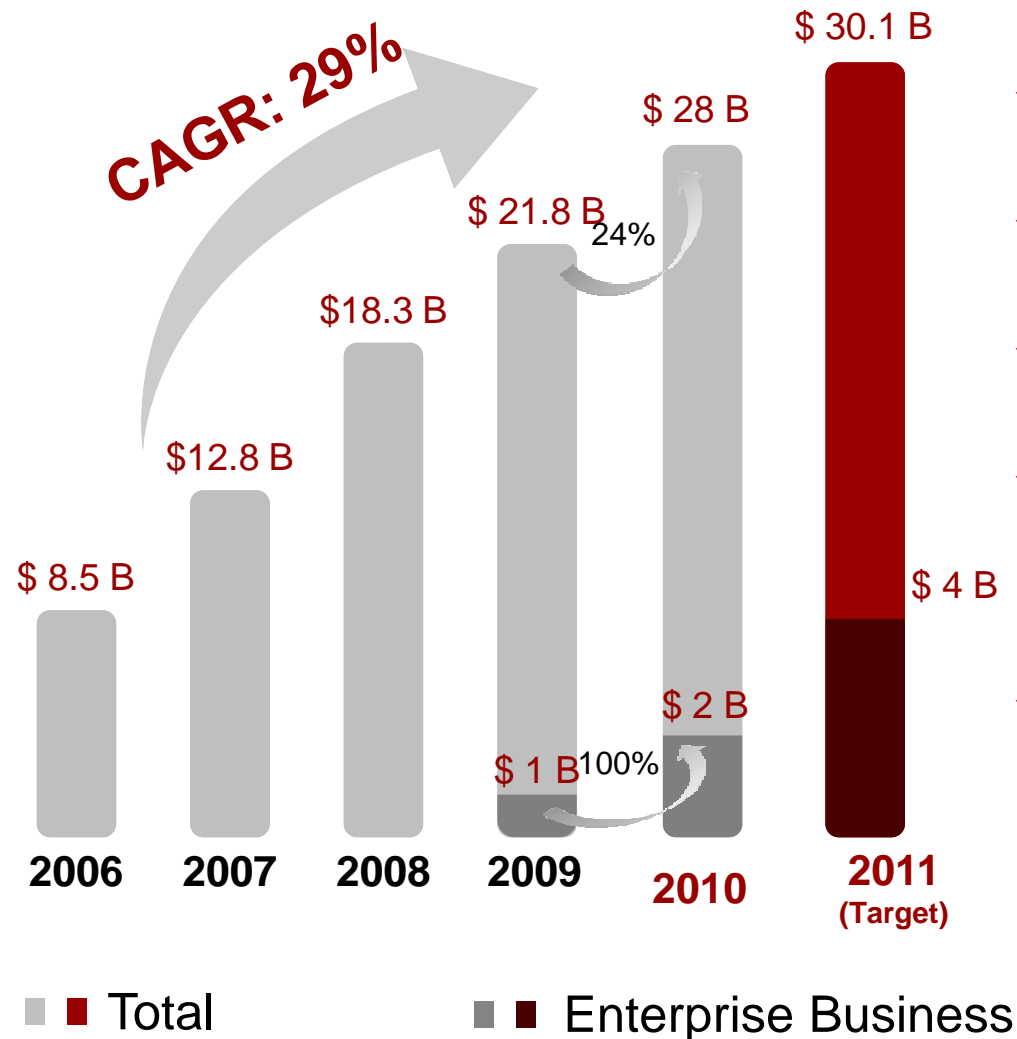

- ✓ Ranked **352** in the Fortune Global 500
- ✓ **120 000** employees worldwide
- ✓ **44%** of employees working in R&D
- ✓ Serving **45** of the world's top 50 telecom operators
- ✓ Enterprise business is the strategic direction of Huawei in the coming years

Patent applications by country of origin

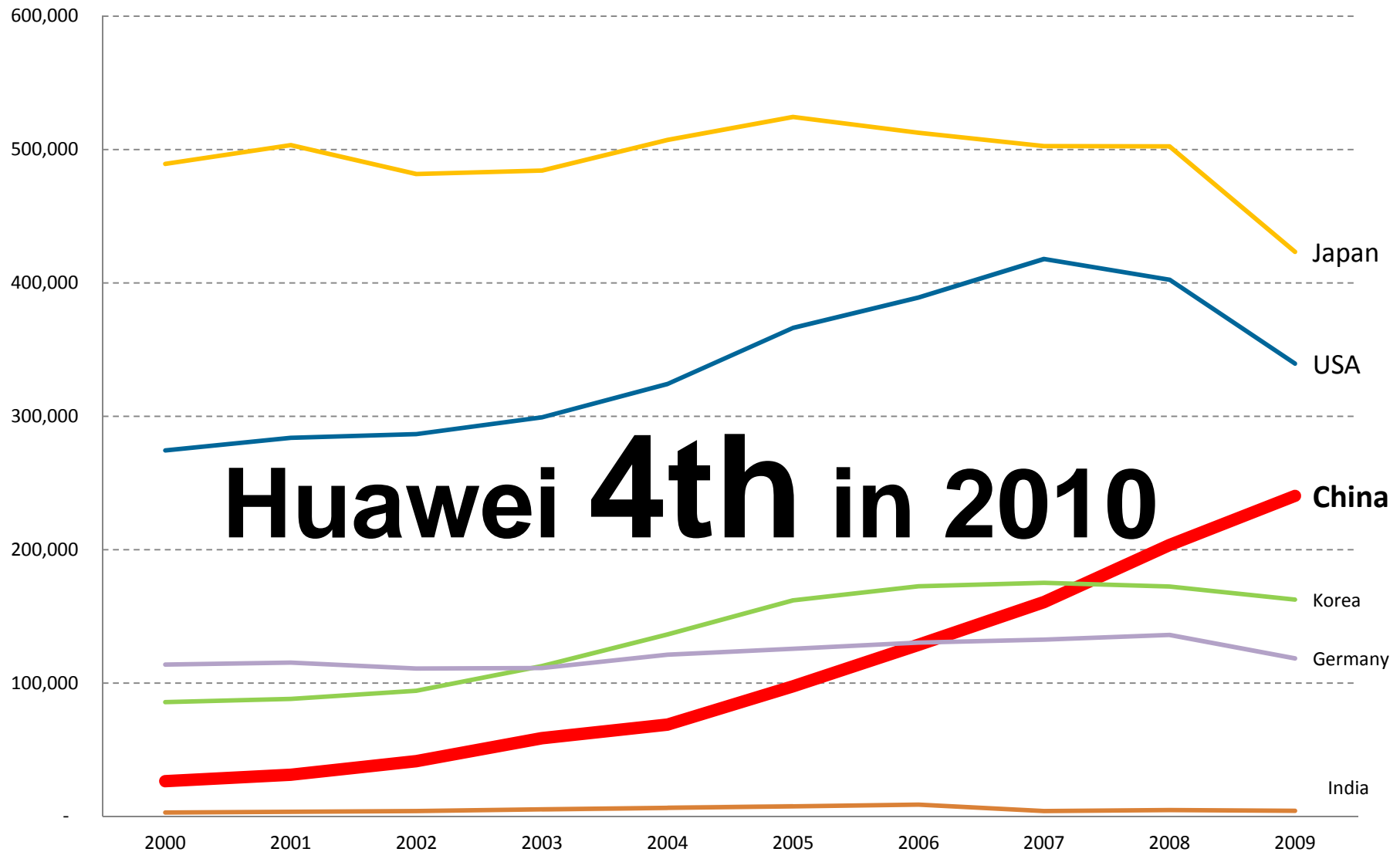

Source: World Intellectual Property Organization Indicators 2010

Most Innovative Companies – 2010

FAST COMPANY

Top 10

| | |
|----------------|--------------|
| 1. Facebook | LAST YEAR 15 |
| 2. Amazon | LAST YEAR 9 |
| 3. Apple | LAST YEAR 4 |
| 4. Google | LAST YEAR 2 |
| 5. Huawei | NEW ! |
| 6. First Solar | LAST YEAR 18 |
| 7. PG&E | NEW ! |
| 8. Novartis | NEW ! |
| 9. Walmart | LAST YEAR 33 |
| 10. HP | LAST YEAR 12 |

Huawei - One-Stop Shop for IP Solutions

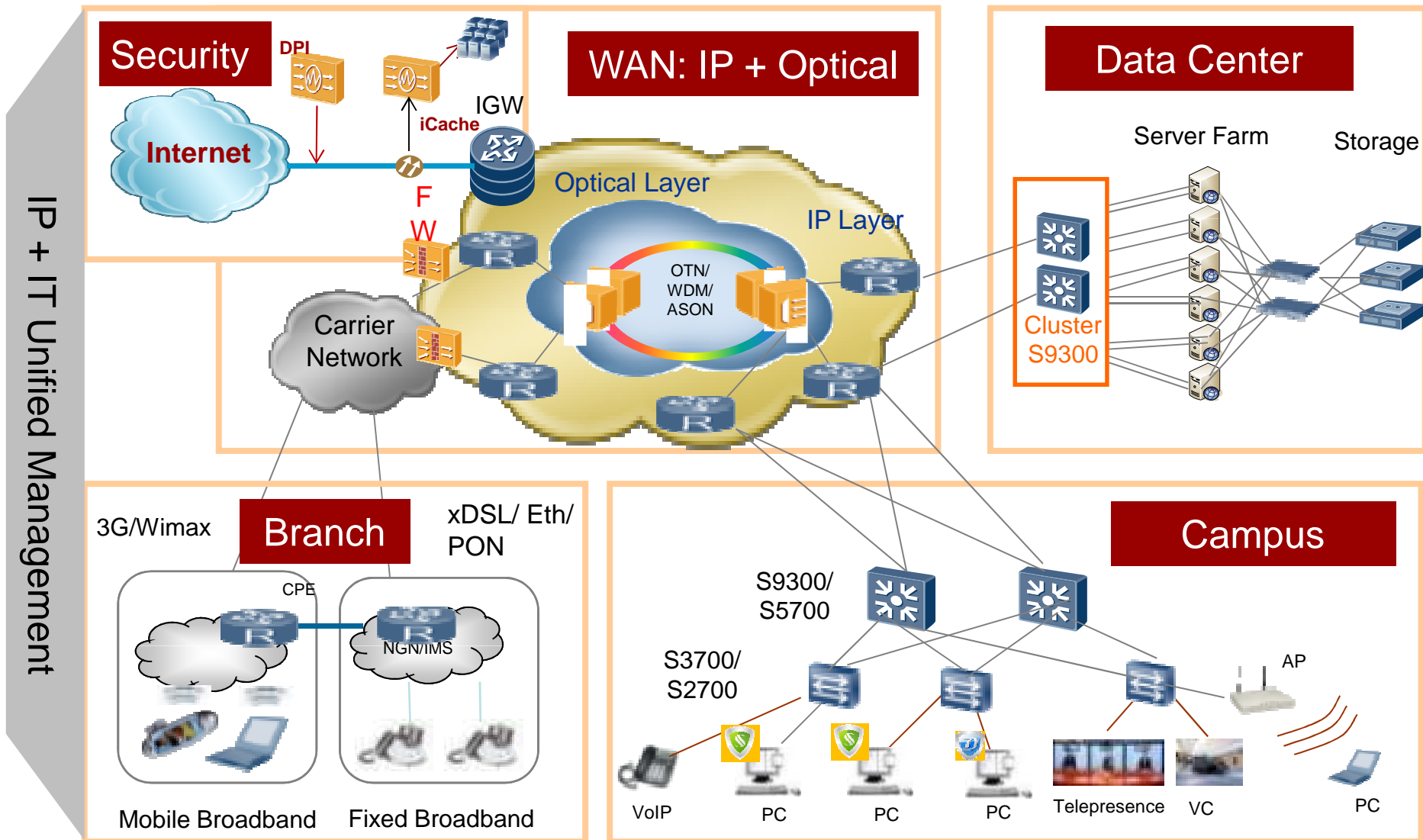

Complete IP products portfolio

Router

Access Router



AR 200 AR 1200 AR 2200 AR 3200

Edge Router



NE 20E

Core Router



NE40E-X1/X3/X8/X16 NE5000E

LAN & WLAN

Core Switch



S9300

10GE DC Switch

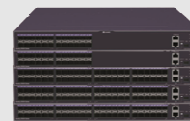

S6700

Aggregation and access



S7700

S5700

S3700

FE Access



S2700

SMB



S1700

WLAN AP



WA603

WA633

WA653





WLAN AC









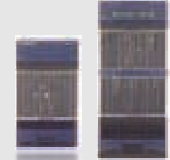

WS6603
AC card in
S9300

Complete IP products portfolio

| | | | | | | |
|-------------------------|-------------------|---------------------------------|------------------------------------|----------------|------------------------|-----------------------|
| Security Service | Capability | Botnet signature knowledge base | Spam knowledge base | Service | Emergency Response | Security Mgmt |
| | | Protocol knowledge base (DPI) | URL signature knowledge base | | On-line upgrade | Security Mgmt service |
| | | Virus signature knowledge base | Intrusion signature knowledge base | | Credibility assessment | Security consulting |

| | | | | | |
|-------------------------------------|--|--|--|--|--|
| Network and content security | Deep Packet Inspection (DPI) | | Anti-DDoS Solution | | |
| | Inline serials SIG9810  ~ 40G | SIG9820  ~ 100G | Eudemon1000E (-X)  1-2G | Eudemon 8000E DDoS  10G-80G | ATIC  Management center |

| | | | | | |
|-----------------------------|--|--|---|---|--|
| Security and content | Enterprise Gateway | Firewall / UTM | | | SSL VPN |
| | EGW2100/2200/3200  160K-1500KPPS | Eudemon 200E-X  0.1~10G | Eudemon 1000E-X  2G-20G | Eudemon 8000E-X  10G-160G | SVN 3000  2000 users |

| | | | | |
|--------------------------|--|--|---|--|
| Security Software | Endpoint Security Management | | Security Management System | |
| | TSM  Terminal Security Mgmt | DSM  Document security Mgmt | eLog  Log Mgmt and Audit | VSM  unified management |

Complete IP products portfolio

Transmission

WDM



OSN1800 OSN6800 OSN8800

MSTP



Metro1000/100 OSN550/500
OSN1500/2500/3500/3500II/7500/9560

Microwave



RTN 910 RTN950 RTN980

Access & Mobile

WiMax



BTS Terminal

GPON OLT



MA5600T

GPON ONU



MA561x/2x/3x

GSM-R



DBS 3900

Network Management

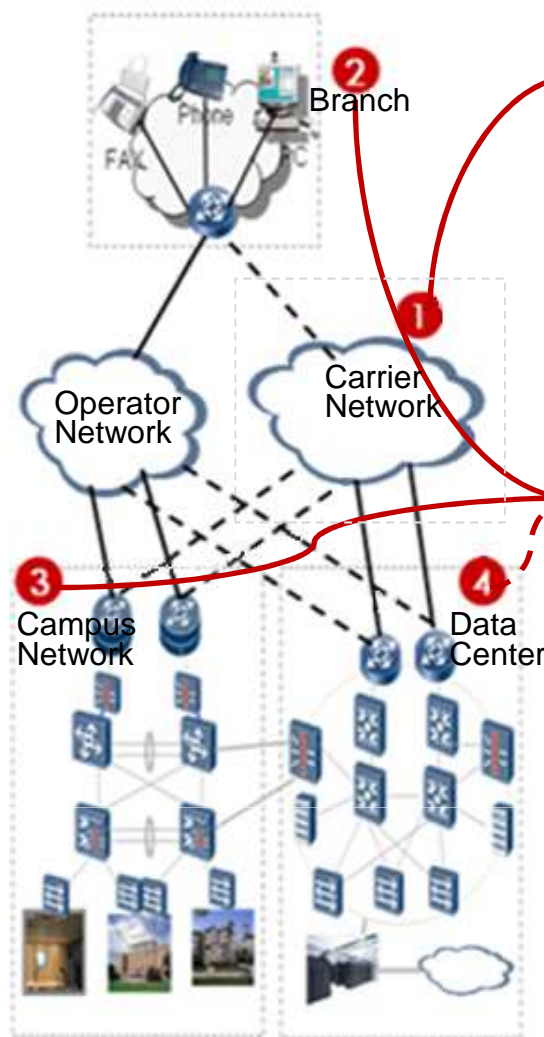

Operator

U2000

Unified Management, Visualized O&M:

- Unified Manage IP & Transport & Access Devices
- Visualized Service Management
- Service Based Authorization Management
- Multi-Protocols Northbound Interface
- Need install Client

Enterprise

eSight

IT Easy Care:

- IT & IP Unified management
- Other Vendors devices Unified management (CISCO, H3C)
- Devices Configuration in bulk
- Customized Report
- Open Redevelopment Platform
- Browser as the client

Huawei UC and IP Telephony

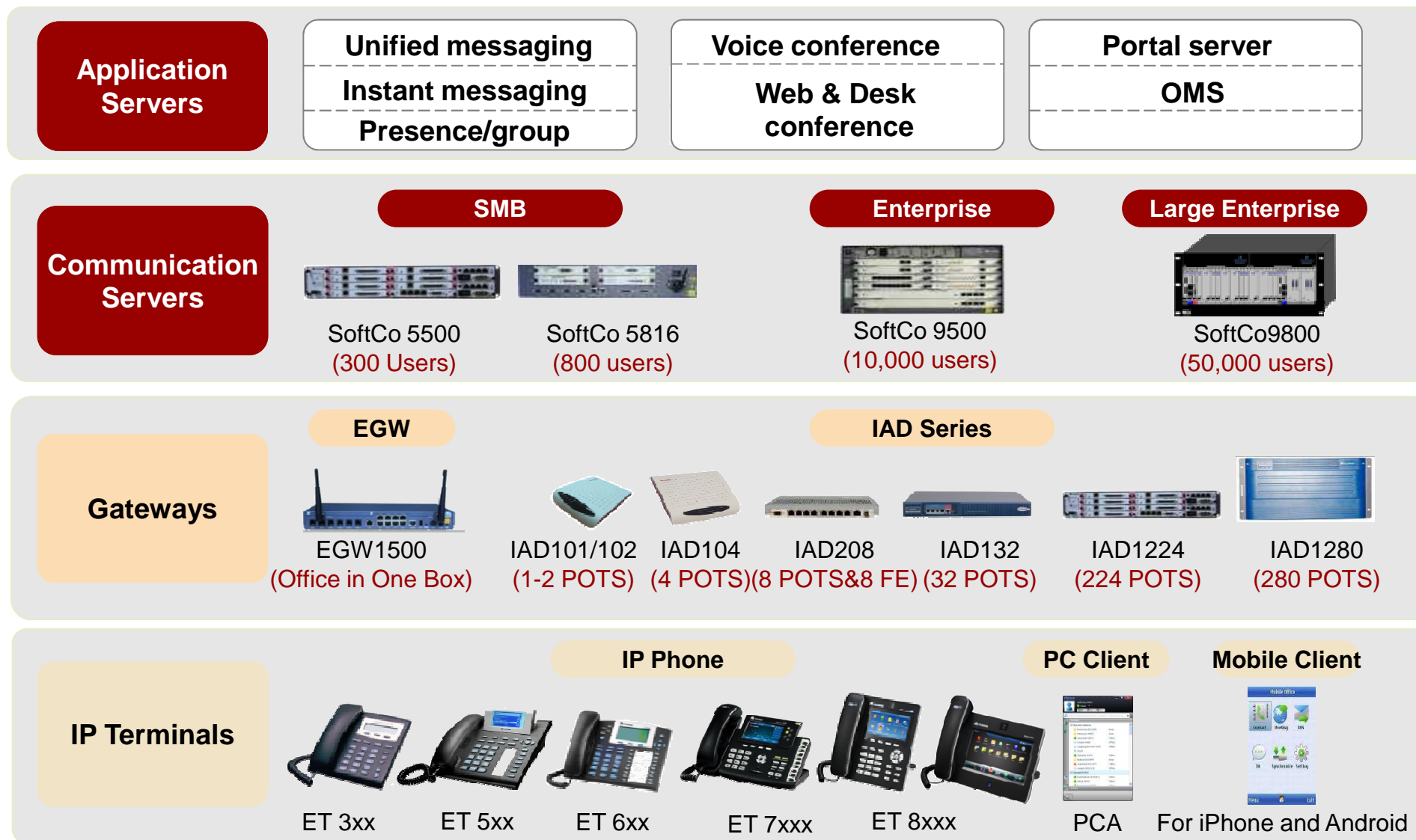

Huawei IP Contact Center

Applications



Cloud management platform



Cloud agent server



HPS

Middle ware



Smart CTI



MRS



ASR Server



TTS Server



IVR



Recording



Report

ACD

SMB



UAP2100 20agents

Enterprise



UAP3300 240 agents

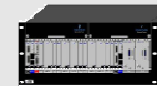

UAP6600 1000 agents

Large Enterprise



UAP8100 20000agents

Gateways

IAD Series



IAD101/102
(1-2 POTS)



IAD104
(4 POTS)



IAD208
(8 POTS&8 FE)



IAD132
(32 POTS)



IAD1224
(224 POTS)



IAD1280
(280 POTS)

IP Terminals

IP Phone



ET 3xx



ET 5xx



ET 6xx



ET 8xx

PC Client



Softphone

Thin client



Wyse S10

Huawei Video Communication

Telepresence



TP1002



TP3006



TP3016



TP3106

VC Endpoint

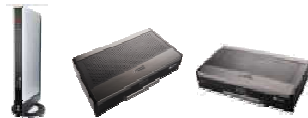

VP903x



VP806x



VP803x



MC850/1

MCU & TP Server



MCU8660



MCU8650



MCU8650C



VP8066-M



VP9039-M VP8039-M

Mgmt. Suite

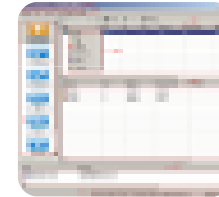

vSwitch

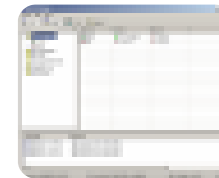

vBill



GK&RM



PC Server

Accessories



VPC510



VPC520



M220



M210



DSR

Huawei IT Infrastructure Products

Cloud Products

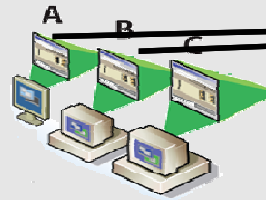

VDI
(Virtual Desktop Infrastructure)

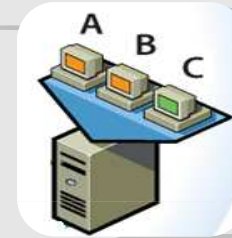

Storage Products



NAS



SAN



VIS



VTL

Server Products



RH1285



RH2285
Rack server



RH5485



E6000
Blade server



X6000
Cloud server

Kraków, Sept. 30th 2011.

**Transforming ideas into
great potential.**

Realize Your Potential

Core Routers' Architecture

Marcin Mazur, CCIE #24210
IP Solutions Manager, CEE&Nordics

www.huawei.com

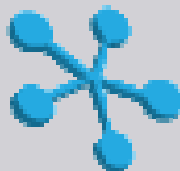

euronog
european network operation group



NE5000E Cluster Architecture

- **Solution Overview**
- Cluster Feng Shui
- Back-to-back Capability

Huawei Cluster Router – NE5000E



■ Large Capacity and Scalability

- World's first 100G End-to-End solution
- 100G/200G flexible LPU
- Unified B2B cluster router



■ Granular Carrier-Class Reliability

- Distributed module schedule in VRP
- Virtual Router, Granular fault isolation
- ISPM, ISHE



■ Sustainable Green Philosophy

- Lower power consumption, EER<3W/G
- Bi-Direction compatible design
- Simplify O&M, service deployed on demand

Cluster Components

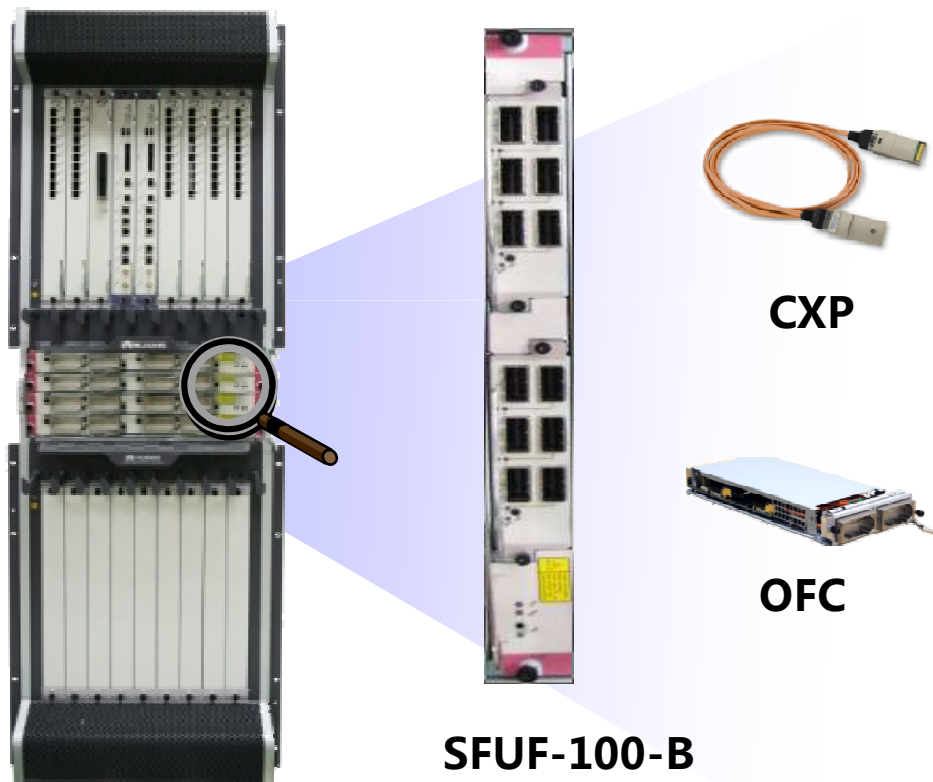

Flexible Deployment

- SFUF-100-B supports flexible OFCs
- Flexible deployment based on requirements
- Smooth upgrade to 100G system

Smooth Expansion

- 40G CCC smoothly expanded to 100G CCC
- Support full 100G cluster system
- Support hybrid 100G cluster with old CLC
- 40G cluster smoothly up to 100G cluster to protect carriers' investment

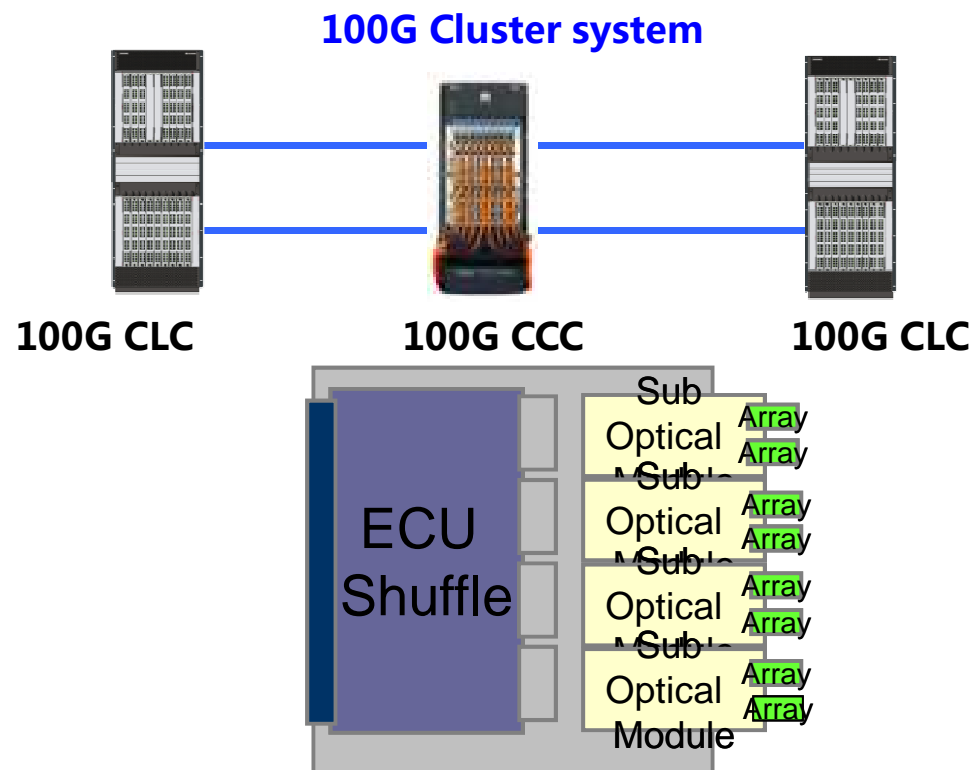

Leading Solar Self-Developed Chipset

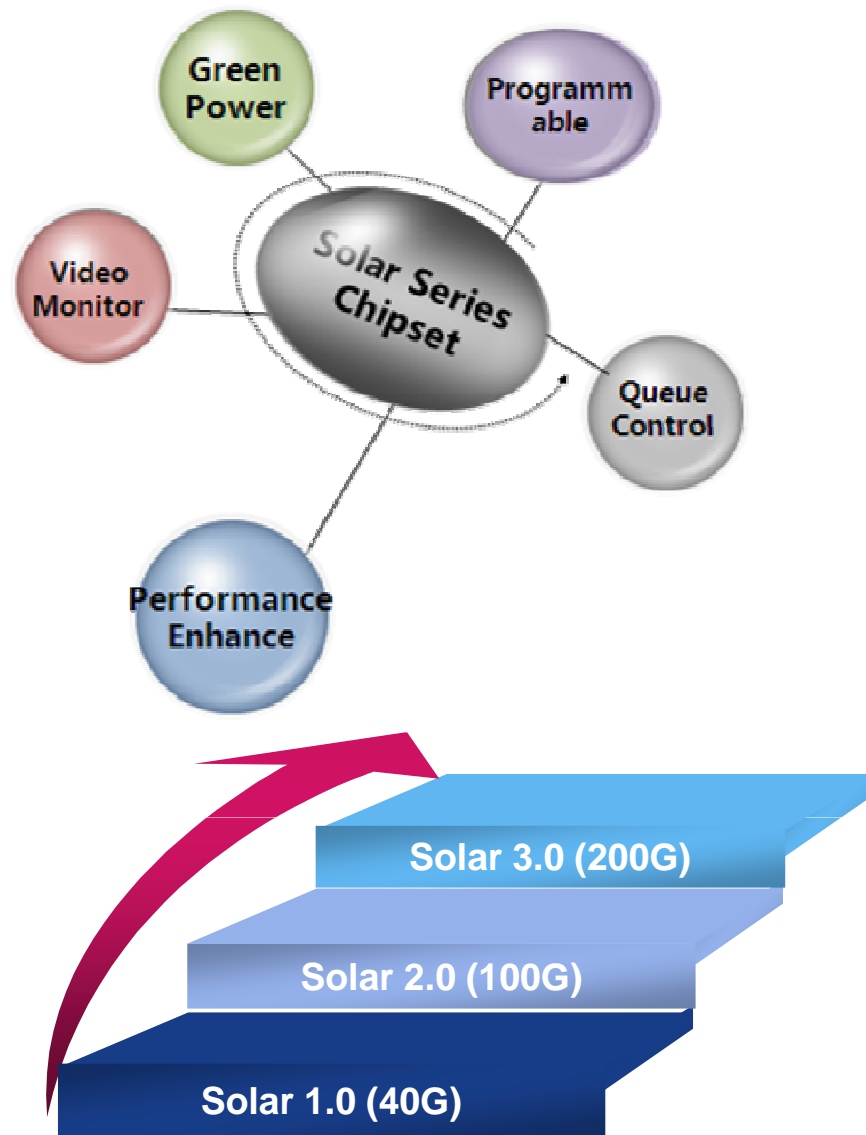
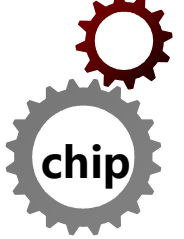

Solar 2.0 Chipsets



Four Chipsets Included - PP2.0, TM&FIC2.0, SF2.0 and ASE2.0 .

R&D in 2005, available in 2009.

Designed for carrier routers, based on 65nm process technology.

- **PPP2.0(Packet Processor 2.0)** - High speed packet processing and forwarding ASIC, optimized for Ethernet/IP/MPLS, 100Gbps(up to 100Mpps) wire-speed throughput, integrated 29 programmable VLM cores.
- **TM&FIC2.0(Integrated TM and FIC 2.0)** - ASIC integrating traffic management and switching fabric buffering function, 100Gbps wire-speed throughput, 5-level Hierarchical scheduling(5-level H-QoS).
- **SF2.0(Switch Fabric 2.0)** - Exchange and arbitration ASIC for router and OTN system, 800Gbps wire-speed throughput. Supporting maximum 3.2T switching system with TM&FIC2.0.
- **ASE2.0(Algorithm Search Engine 2.0)** - high-speed algorithm searching ASIC, providing high performance and large capacity entries with PP2.0.

Flexible LR for Multi-Service Application

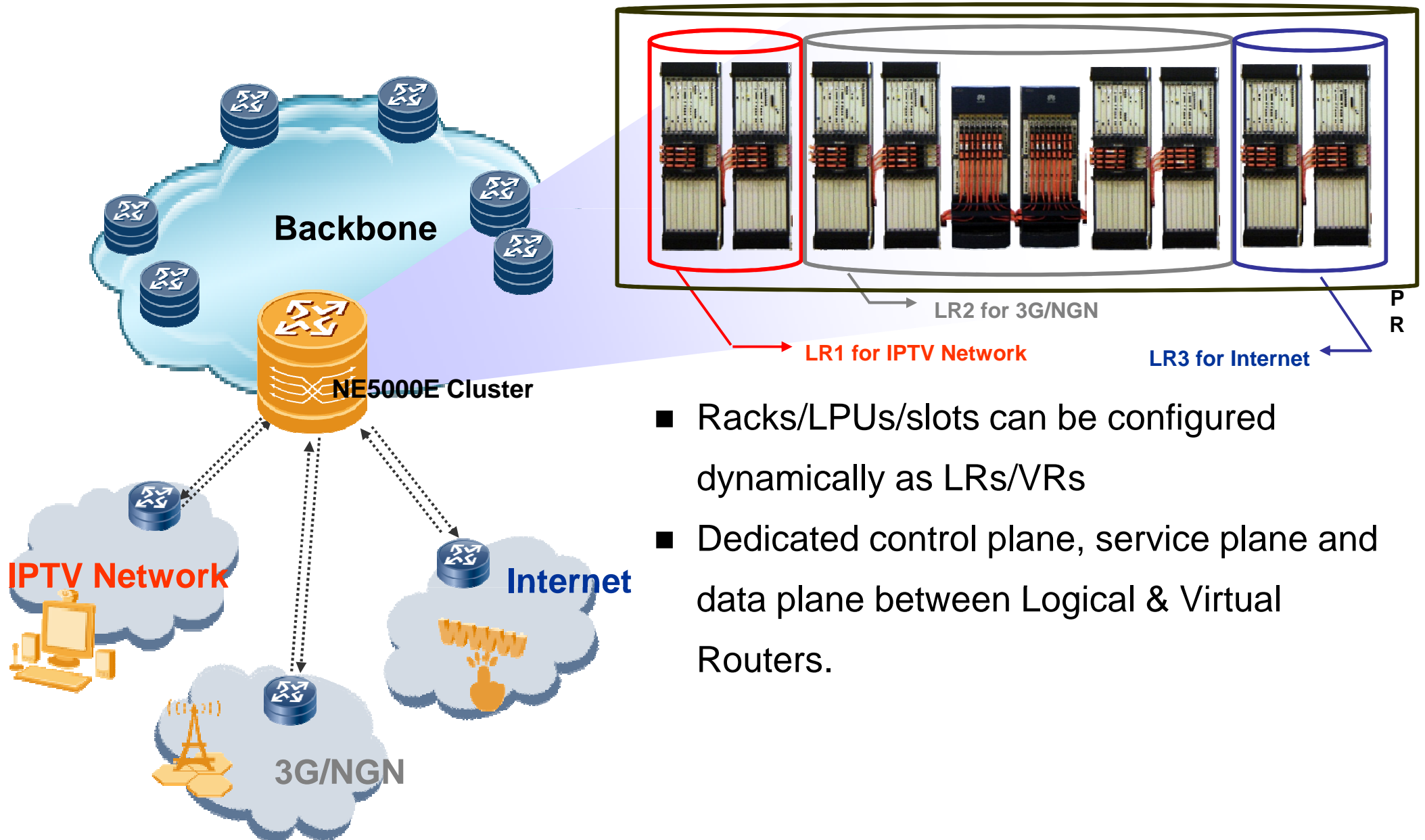

NE5000E Cluster Architecture

- Solution Overview
- **Clustering Feng Shui**
- Back-to-back Capability

Non-Blocking Switching Fabric of NE5000E-X16

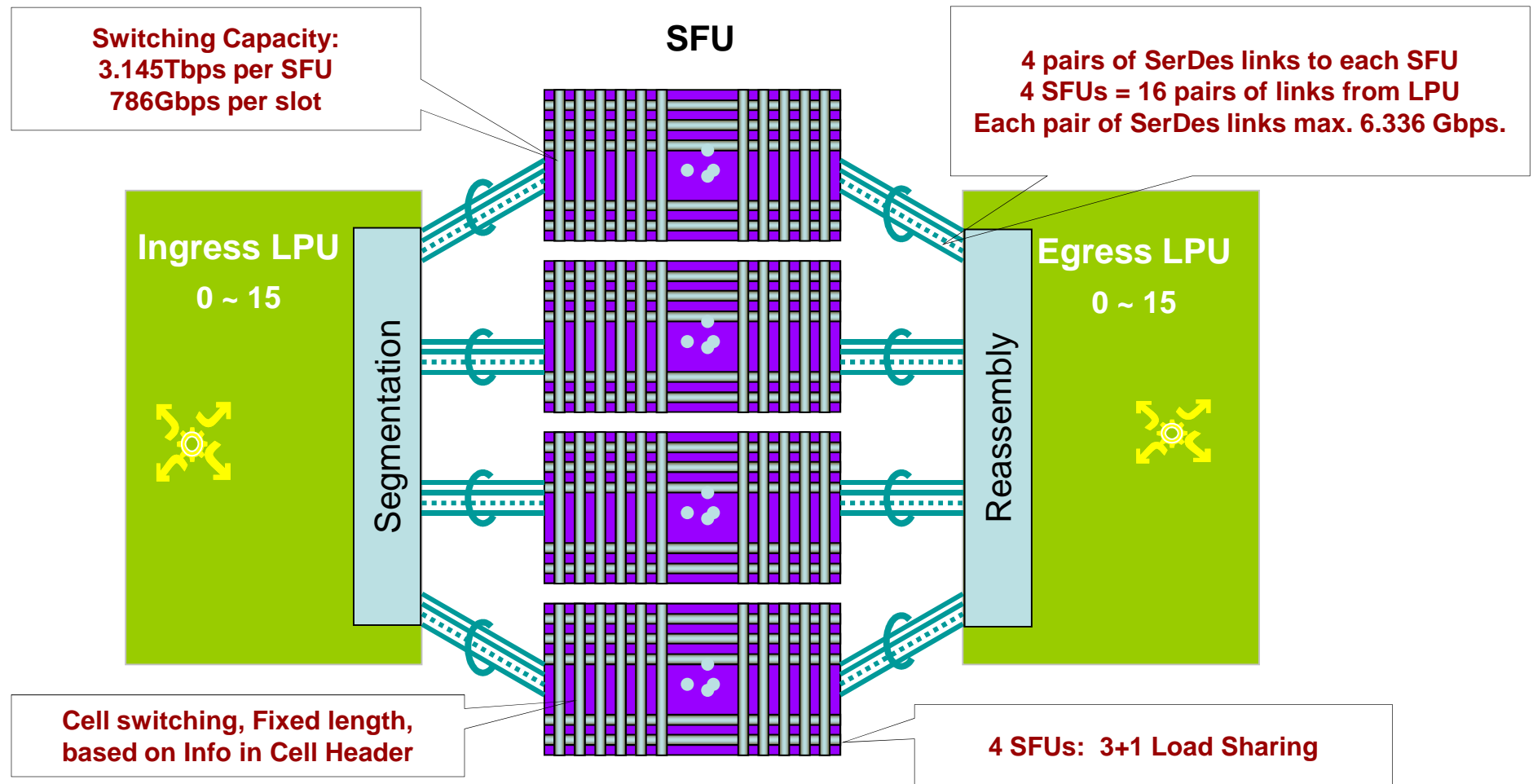

Switching capacity of each SFU is max 3.145Tbps, the whole system: 12.58Tbps.

Multistage Switch Fabric - CLOS

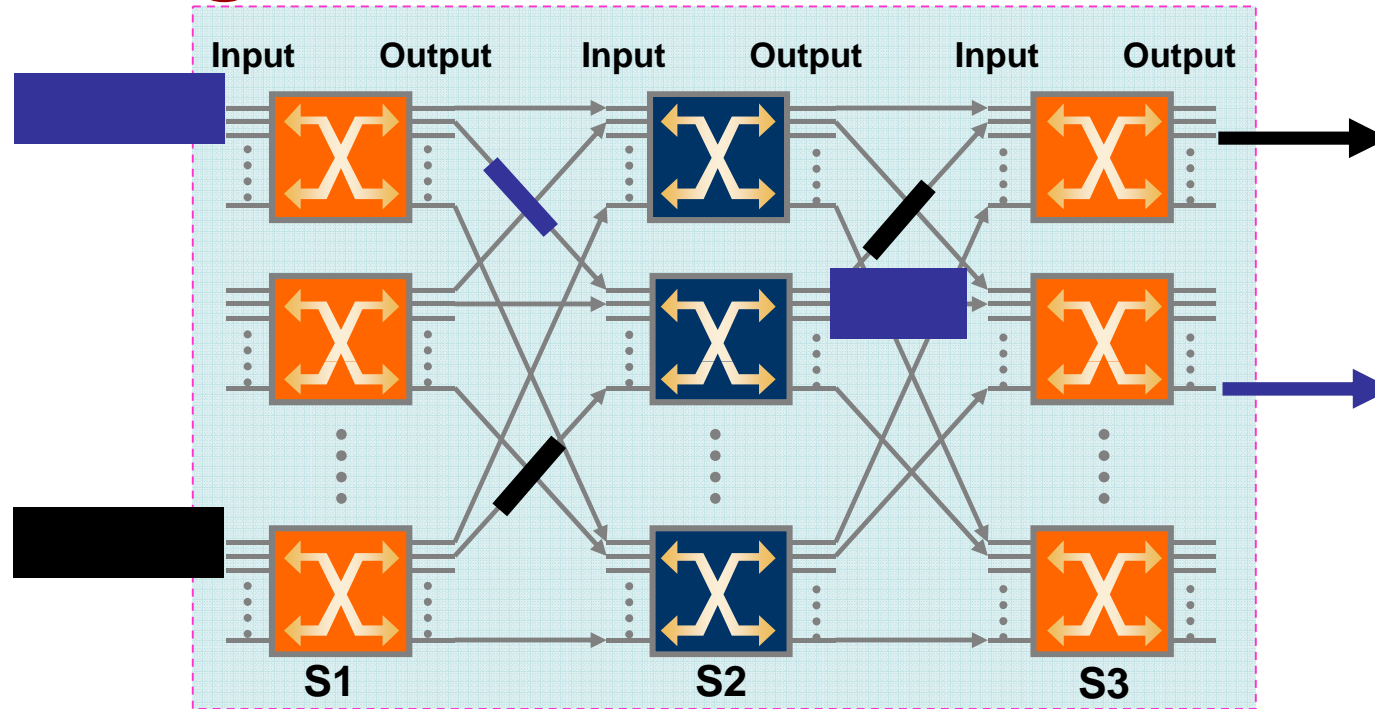

- Introduced by Charles Clos to address performance issues of telephone switching system
- The theory of CLOS: $C(n,m,r)$ model, $S1 \rightarrow S2 \rightarrow S3$.
- If $In = Out$ ($n=m$) rearrangeably non-blocking. Multiple non-blocking paths
- For S2, 64x64 switch chipset can be automatically divided into certain numbers of 32x32, 16x16, 8x8, 4x4 switching fabrics.

128 In X 128 Out - Single Stage vs Multistage

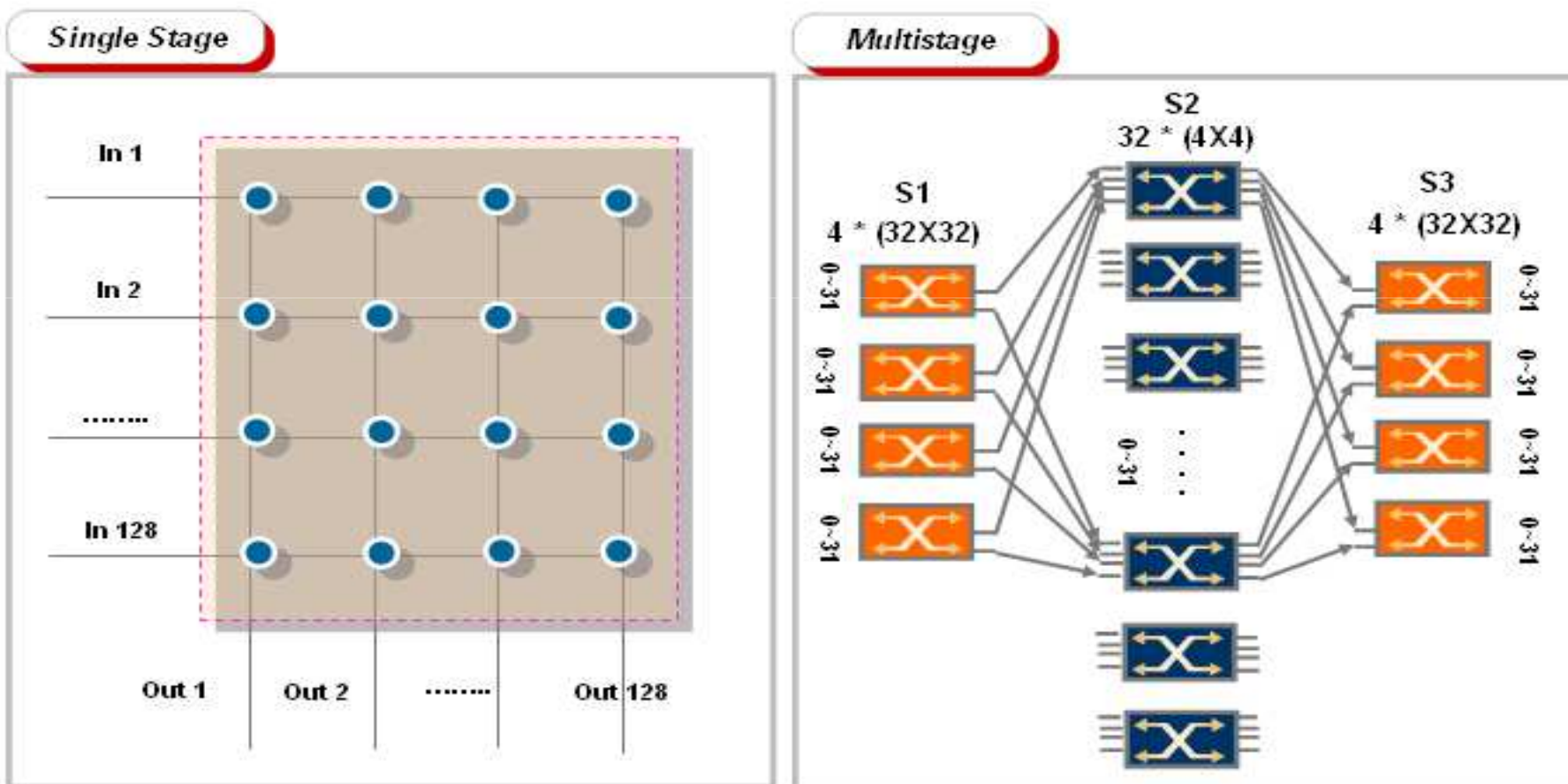

- Single Stage Switch Fabric: 128 In X 128 Out = **16384** crosspoints
- Multistage CLOS Switch Fabric: $4*(32X32)+32*(4X4)+4*(32X32) = 8704$ crosspoints
- It is difficult for single stage switch mode to realize non-blocking connections between input and output node.
- 3-stage switch mode is more flexible and reduces cluster's crosspoint number.

Flexible Switching Matrix

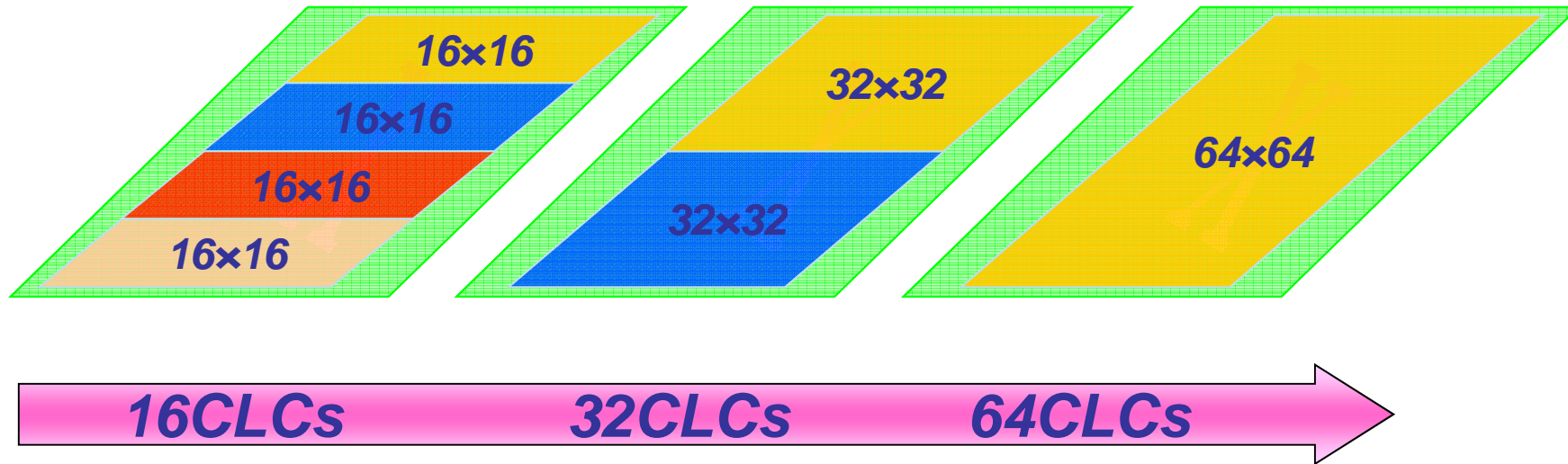

- 4+16/ 8+32/16+64 mode
- 16x16/32x32/64x64 switching matrix
- Each chip has 4/2/1 switching plane.
- Each switching plane is connected to 16/32/64 CLCs.
- Each CCC has 4/2/1 switching planes.

- Flexible and on-demand configuration of OFCs
- Flexible adjustment of the switching chips' switching modes
- Flexible adjustment of the switching chips' switching matrixes
- Flexible expansion of the switching matrix without hardware replacement

Multi-plane Multistage Switching Fabric

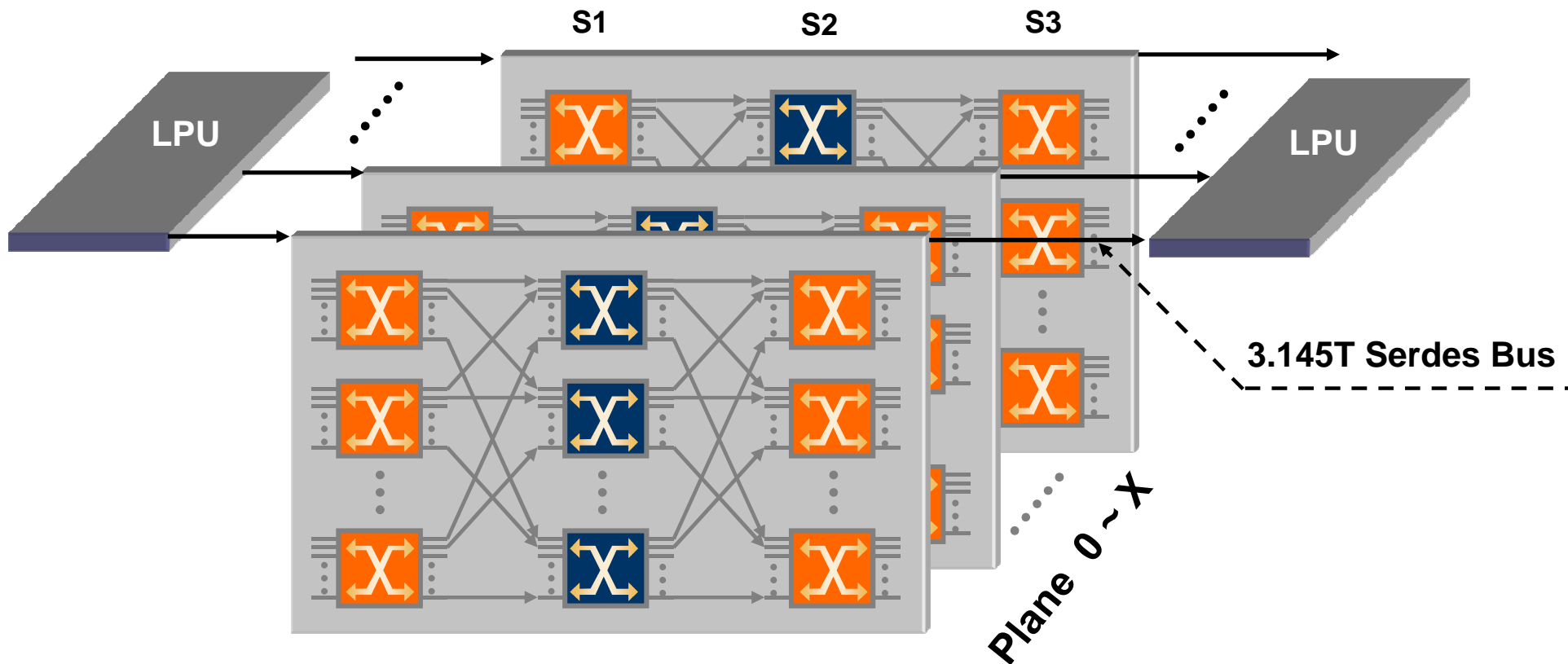

- Multi-plane Multistage CLOS Switch Fabric – providing high reliability and huge capability.
- Each plane is the three-stage switch architecture – S1, S2 and S3.
- The LPU forwards packets to different planes and the data is only switched in each plane, no inter-planes.

NE5000E Cluster Architecture

- Solution Overview
- Cluster Feng Shui
- **Back-to-back Capability**

Innovative Huawei B2B Cluster

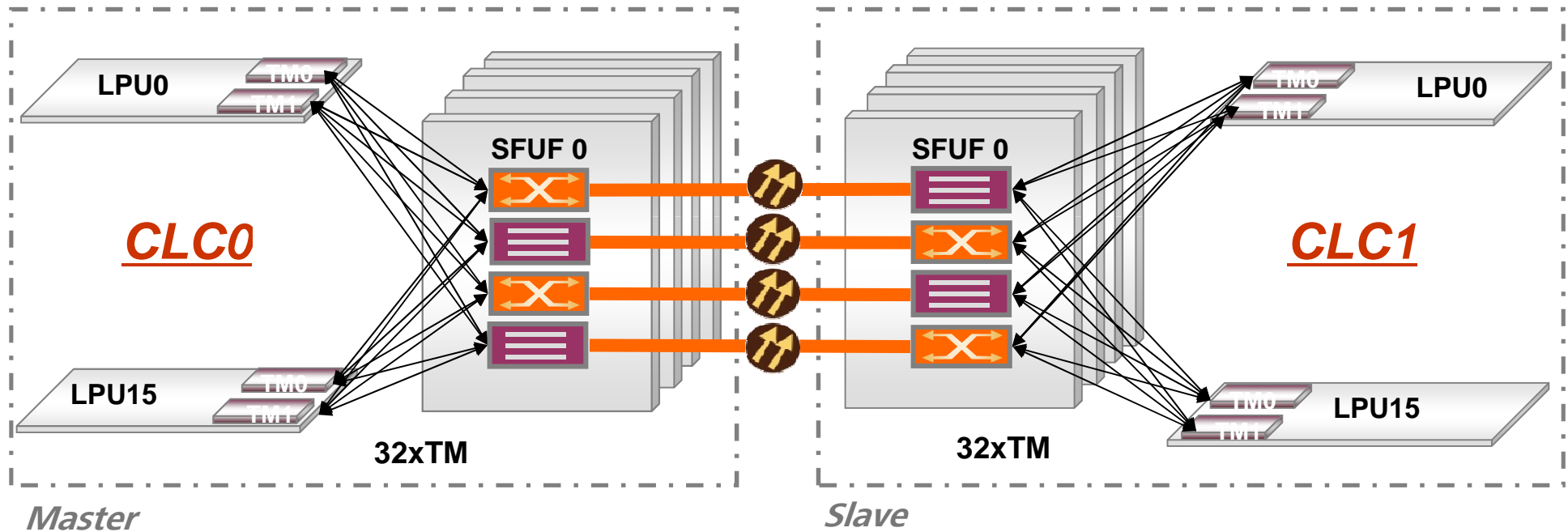

 Pass Mode  64X64 Switch

- Master and slave chassis connected via inter-chassis channels.
- 2048x2048 non-blocking switch distributed in 8 pcs of SFUF.
- 8 Switching Chipsets per CLC work in Pass mode.
- 8 Switching Chipsets per CLC work in 64X64 switch mode.
- 6.4Tbps switching Capacity.

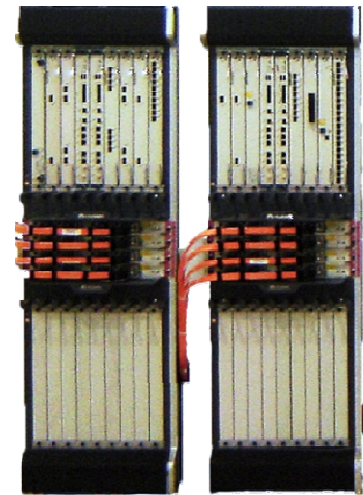

Flexible and Dynamic Switch Mode

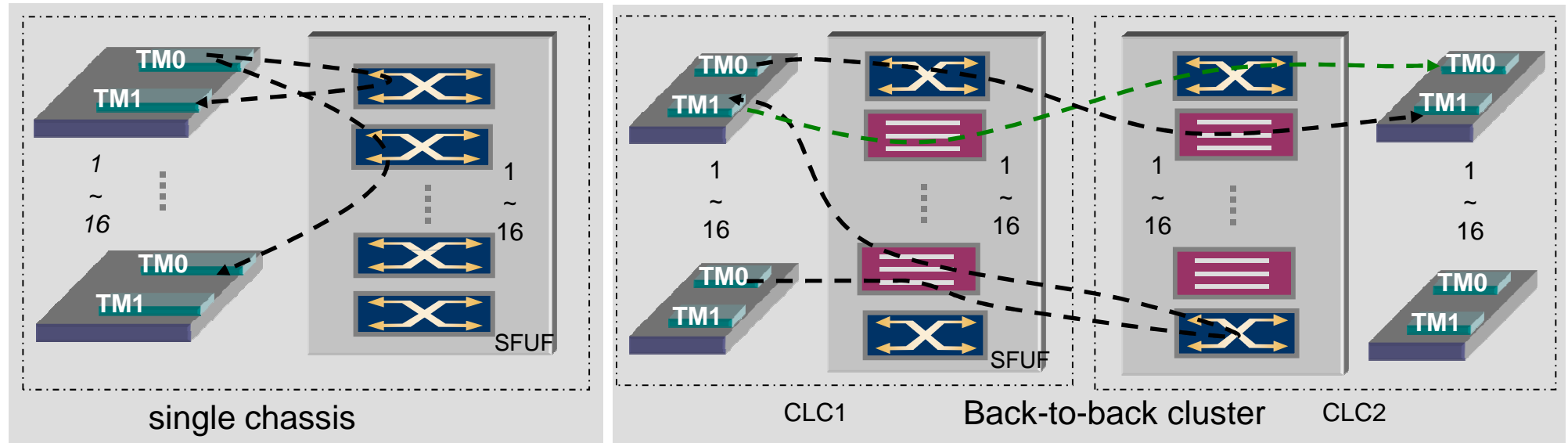

Single Chassis:

- Each SFU has 4 switch plane. 4 SFU have $4 \times 4 = 16$ switch plane.
- Switch mode of every plane configured to S2 mode.
- Every TM connect to all switch plane.

B2B Cluster:

- 2 CLC have 8 SFU, all SFU have $4 \times 8 = 32$ switch plane.
- Every CLC has 8 switch planes configured to S2 mode (switch granularity is 64×64), other 8 switch planes configured to S2 pass mode.
- 16 switch plane switch mode is S2 mode, 16 switch plane switch mode is S2 pass mode
- Every TM connect to all switch plane



S2 Pass Mode: direct connection from Input to Output

S2 Mode: switch connection from Input to Output

Logical Topology of the Switching Network

- On a single CLC, each switching plane uses a 32x32 cross-connection matrix by default (16 slots, with 2 serdes buses in each slot)
- In a back-to-back system, however, there are 32 slots and 64 serdes buses, which require a 64x64 cross-connection matrix.
- Each switching chip uses hence 64x64 cross-connection matrix, which is used for data switching in 32 slots.

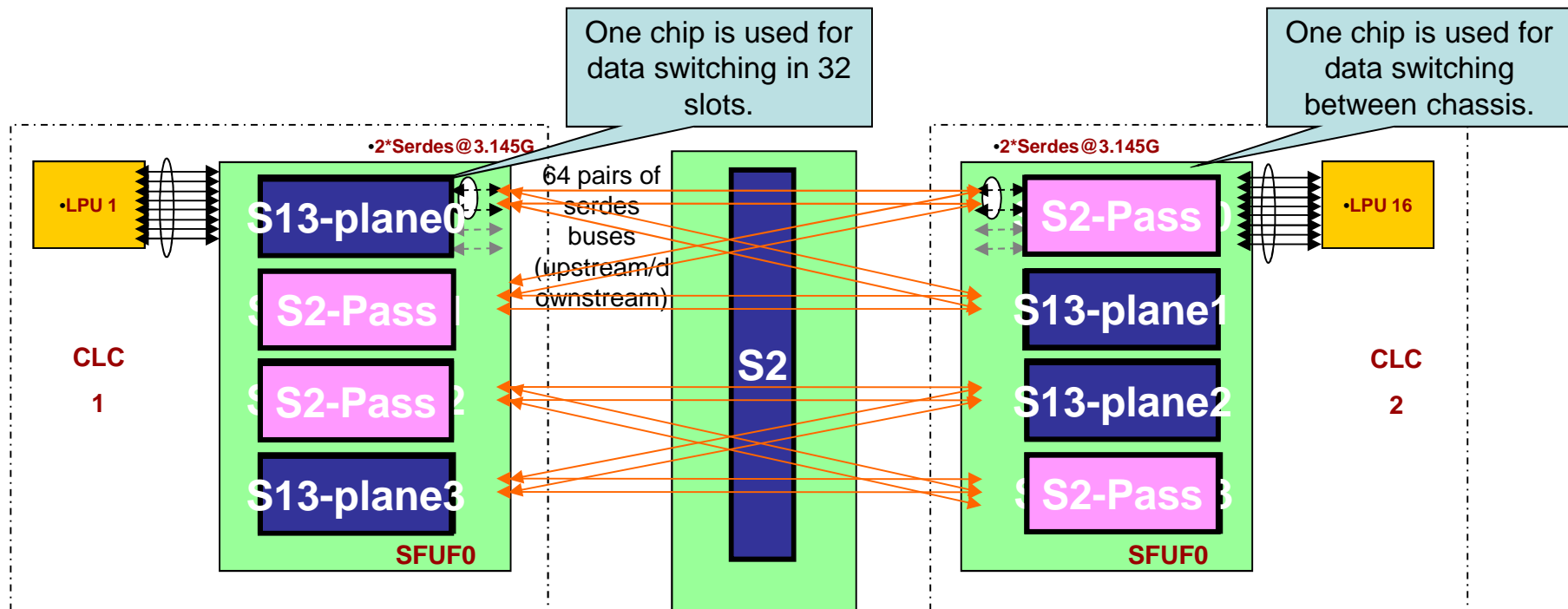

To ensure hardware consistency, exchange the S2 and S13 switching chips.

Hierarchical VR Deployment for B2B System

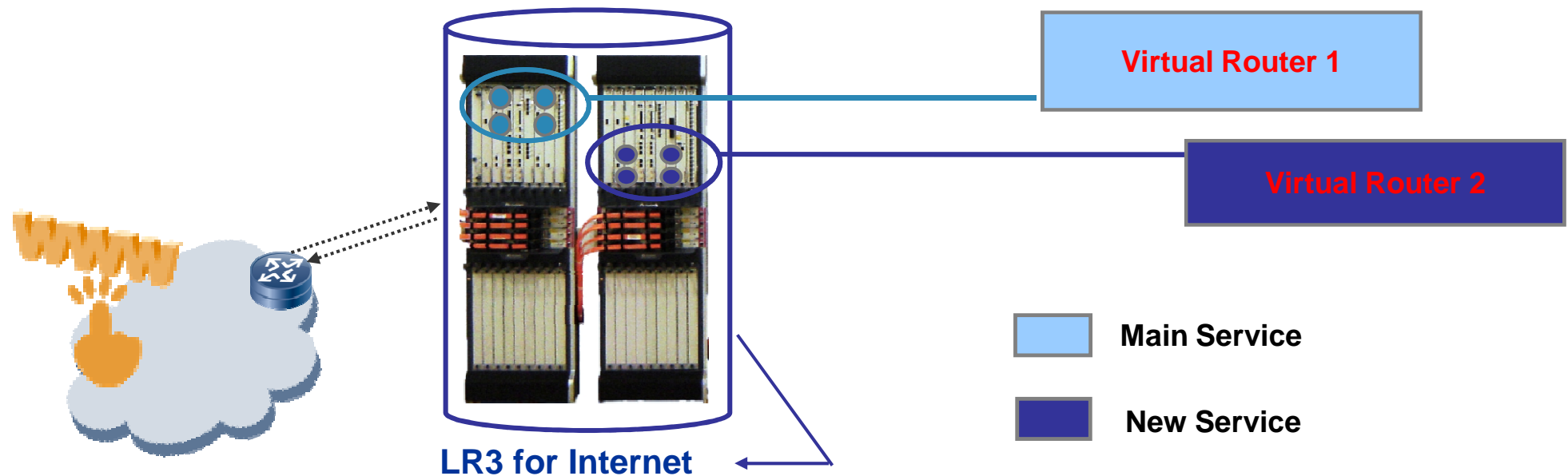

- VR is configured under LR and one LR must contain at least one VR, maybe more than one VR.
- VR has its own Routing Protocol and OM. Different VRs use the same software image and share all common resources.
- To validate the feasibility of the new business through deploying the new business in the virtual router.
- With this method the resource is utilized sufficiently and the main business which has already in running is not affected.

Thank you!!

marcin.mazur@huawei.com